

**ISOLATOR SUBMITTAL
 RESTRAINED SPRING, 1" DEFLECTION**

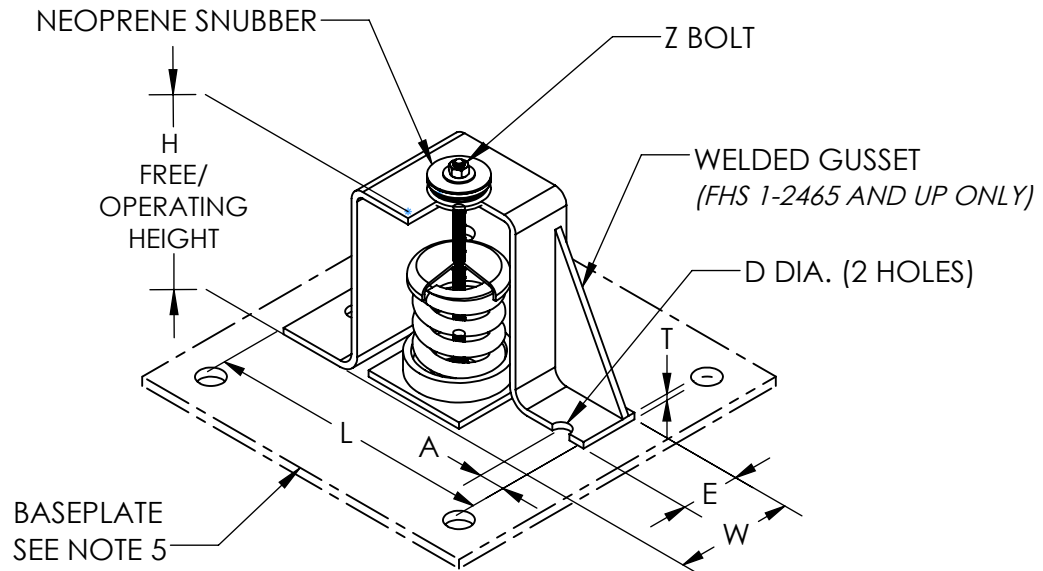

DIMENSIONAL DATA

SIZE	L	W	T	A	D	E	H	Z
1-35/805	7.31	3.00	0.38	0.69	0.44	1.50	6.00	0.50
1-50/1000	9.53	5.00	0.38	0.88	0.81	2.50	7.56	0.63
1-1250/3500	9.53	5.00	0.38	0.88	0.81	2.50	7.56	0.63

MODEL		SPRING COIL					
		COLOR		FREE HT.	O.D.	RATED (LBS)	
TYPE	SIZE	OUTER	INNER			LOAD	DEFL.
FHS	1-35	BLUE		3.19	1.75	35	1.52
FHS	1-70	GREEN		3.19	1.75	70	1.36
FHS	1-120	GRAY		3.19	1.75	120	1.18
FHS	1-220	BROWN		3.19	1.75	220	1.07
FHS	1-370	ORANGE		3.19	1.75	370	0.96
FHS	1-500	BEIGE		3.19	1.75	500	1.00
FHS	1-600	CHROME		3.19	1.75	600	1.00
FHS	1-700	BEIGE	WHITE	3.19	1.75	700	1.00
FHS	1-805	CHROME	WHITE	3.19	1.75	805	1.01
FHS	1-50	BEIGE		4.20	3.00	50	1.00
FHS	1-100	CHROME		4.20	3.00	100	1.00
FHS	1-250	BLUE		4.20	3.00	120	1.79
FHS	1-450	GREEN		4.20	3.00	450	1.54
FHS	1-625	BLACK		4.20	3.00	625	1.44
FHS	1-800	GRAY		4.20	3.00	800	1.31
FHS	1-1000	RED		4.20	3.00	1000	1.15
FHS	1-1250	BROWN		4.20	3.00	1250	1.09
FHS	1-1700	ORANGE		4.20	3.00	1700	0.95
FHS	1-2200	ORANGE	GRAY	4.20	3.00	2200	1.00
FHS	1-2465	BLUE		4.20	3.00	1465	1.00
FHS	1-2865	BLUE	GRAY	4.20	3.00	2865	1.00
FHS	1-3500	BLUE	BROWN	4.20	3.00	3500	1.00

NOTES:

1. VERTICALLY AND LATERALLY RESTRAINED SPRING ISOLATOR.
2. REPLACEABLE NEOPRENE SNUBBER
3. MINIMUM OVERLOAD OF 50%
4. POWDER COATED SPRING ELEMENT, BRACKET IS HOT DIPPED GALVANIZED.
5. FOR ADEQUATE ANCHOR SIZING, TORQUE, AND BASEPLATE REQUIREMENTS, VISIT kineticsnoise.com/seismic/fhs.html

ALL DIMENSIONS ARE IN INCHES

REVISION:	FORM:	REPLACES:
-----------	-------	-----------